

ข้อมูลเกี่ยวกับไมโครคอนโทรลเลอร์ตระกูล PIC

1. โครงสร้างทางสถาปัตยกรรม และฮาร์ดแวร์ของไมโครคอนโทรลเลอร์ PIC16F877 และ PIC16F87X

28/40-pin 8-Bit CMOS FLASH Microcontrollers

Devices Included in this Data Sheet:

- PIC16F873 • PIC16F876
- PIC16F874 • PIC16F877

Microcontroller Core Features:

- High-performance RISC CPU
- Only 35 single word instructions to learn
- All single cycle instructions except for program branches which are two cycle
- Operating speed: DC - 20 MHz clock input
DC - 200 ns instruction cycle
- Up to 8K x 14 words of FLASH Program Memory,
Up to 368 x 8 bytes of Data Memory (RAM)
Up to 256 x 8 bytes of EEPROM data memory
- Pinout compatible to the PIC16C73B/74B/76/77
- Interrupt capability (up to 14 sources)
- Eight level deep hardware stack
- Direct, indirect and relative addressing modes
- Power-on Reset (POR)
- Power-up Timer (PWRT) and
Oscillator Start-up Timer (OST)
- Watchdog Timer (WDT) with its own on-chip RC
oscillator for reliable operation
- Programmable code-protection
- Power saving SLEEP mode
- Selectable oscillator options
- Low-power, high-speed CMOS FLASH/EEPROM
technology
- Fully static design
- In-Circuit Serial Programming™ (ICSP) via two
pins
- Single 5V In-Circuit Serial Programming capability
- In-Circuit Debugging via two pins
- Processor read/write access to program memory
- Wide operating voltage range: 2.0V to 5.5V
- High Sink/Source Current: 25 mA
- Commercial and Industrial temperature ranges
- Low-power consumption:
 - < 2 mA typical @ 5V, 4 MHz
 - 20 µA typical @ 3V, 32 kHz
 - < 1 µA typical standby current

Pin Diagram

Peripheral Features:

- Timer0: 8-bit timer/counter with 8-bit prescaler
- Timer1: 16-bit timer/counter with prescaler,
can be incremented during sleep via external
crystal/clock
- Timer2: 8-bit timer/counter with 8-bit period
register, prescaler and postscaler
- Two Capture, Compare, PWM modules
 - Capture is 16-bit, max. resolution is 12.5 ns
 - Compare is 16-bit, max. resolution is 200 ns
 - PWM max. resolution is 10-bit
- 10-bit multi-channel Analog-to-Digital converter
- Synchronous Serial Port (SSP) with SPI™ (Master
Mode) and I²C™ (Master/Slave)
- Universal Synchronous Asynchronous Receiver
Transmitter (USART/SCI) with 9-bit address
detection
- Parallel Slave Port (PSP) 8-bits wide, with
external RD, WR and CS controls (40/44-pin only)
- Brown-out detection circuitry for
Brown-out Reset (BOR)

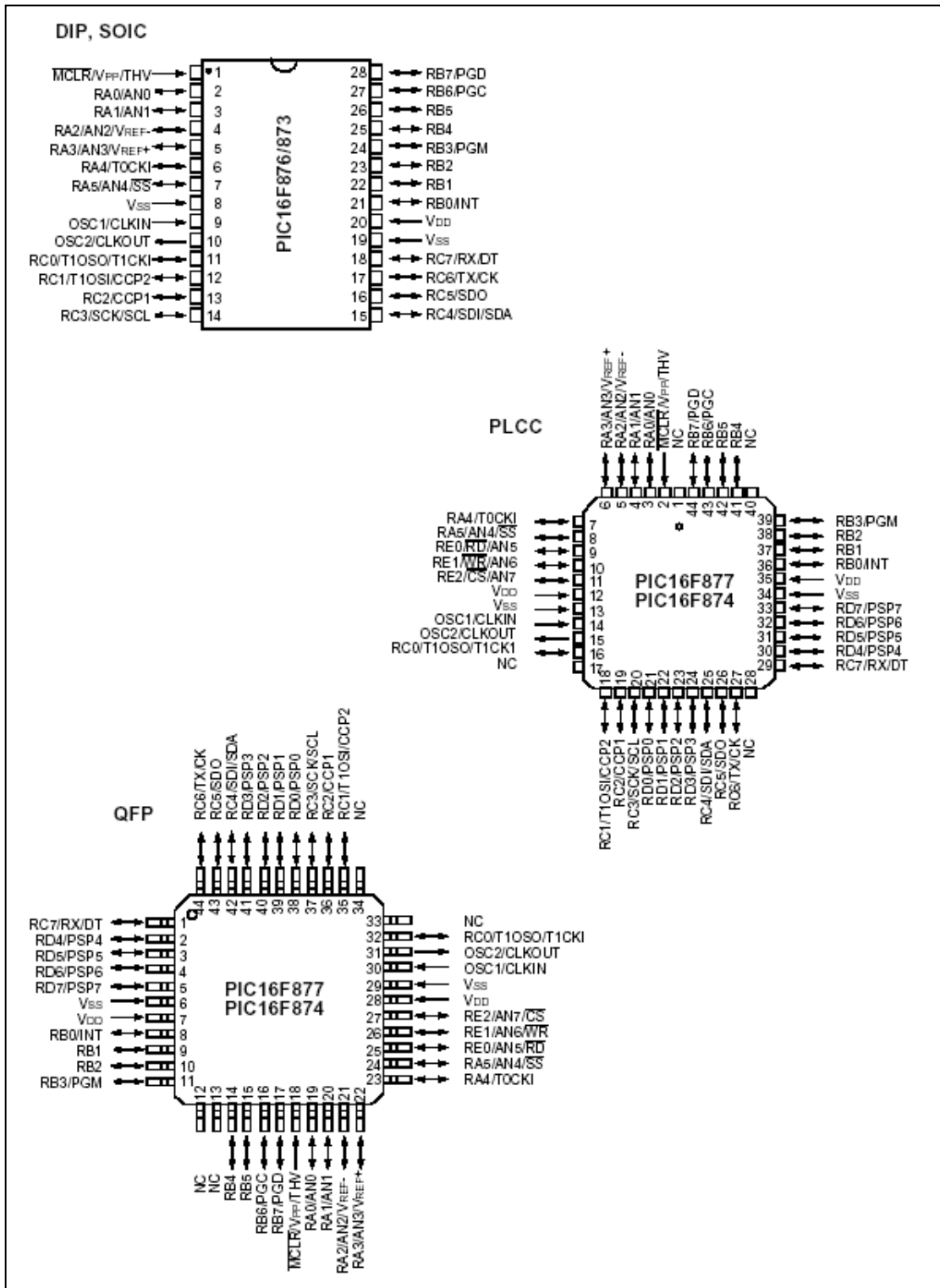

Key Features PICmicro™ Mid-Range Reference Manual (DS33023)	PIC16F873	PIC16F874	PIC16F876	PIC16F877
Operating Frequency	DC - 20 MHz	DC - 20 MHz	DC - 20 MHz	DC - 20 MHz
Resets (and Delays)	POR, BOR (PWRT, OST)	POR, BOR (PWRT, OST)	POR, BOR (PWRT, OST)	POR, BOR (PWRT, OST)
FLASH Program Memory (14-bit words)	4K	4K	8K	8K
Data Memory (bytes)	192	192	368	368
EEPROM Data Memory	128	128	256	256
Interrupts	13	14	13	14
I/O Ports	Ports A,B,C	Ports A,B,C,D,E	Ports A,B,C	Ports A,B,C,D,E
Timers	3	3	3	3
Capture/Compare/PWM modules	2	2	2	2
Serial Communications	MSSP, USART	MSSP, USART	MSSP, USART	MSSP, USART
Parallel Communications	—	PSP	—	PSP
10-bit Analog-to-Digital Module	5 input channels	8 input channels	5 input channels	8 input channels
Instruction Set	35 Instructions	35 Instructions	35 Instructions	35 Instructions

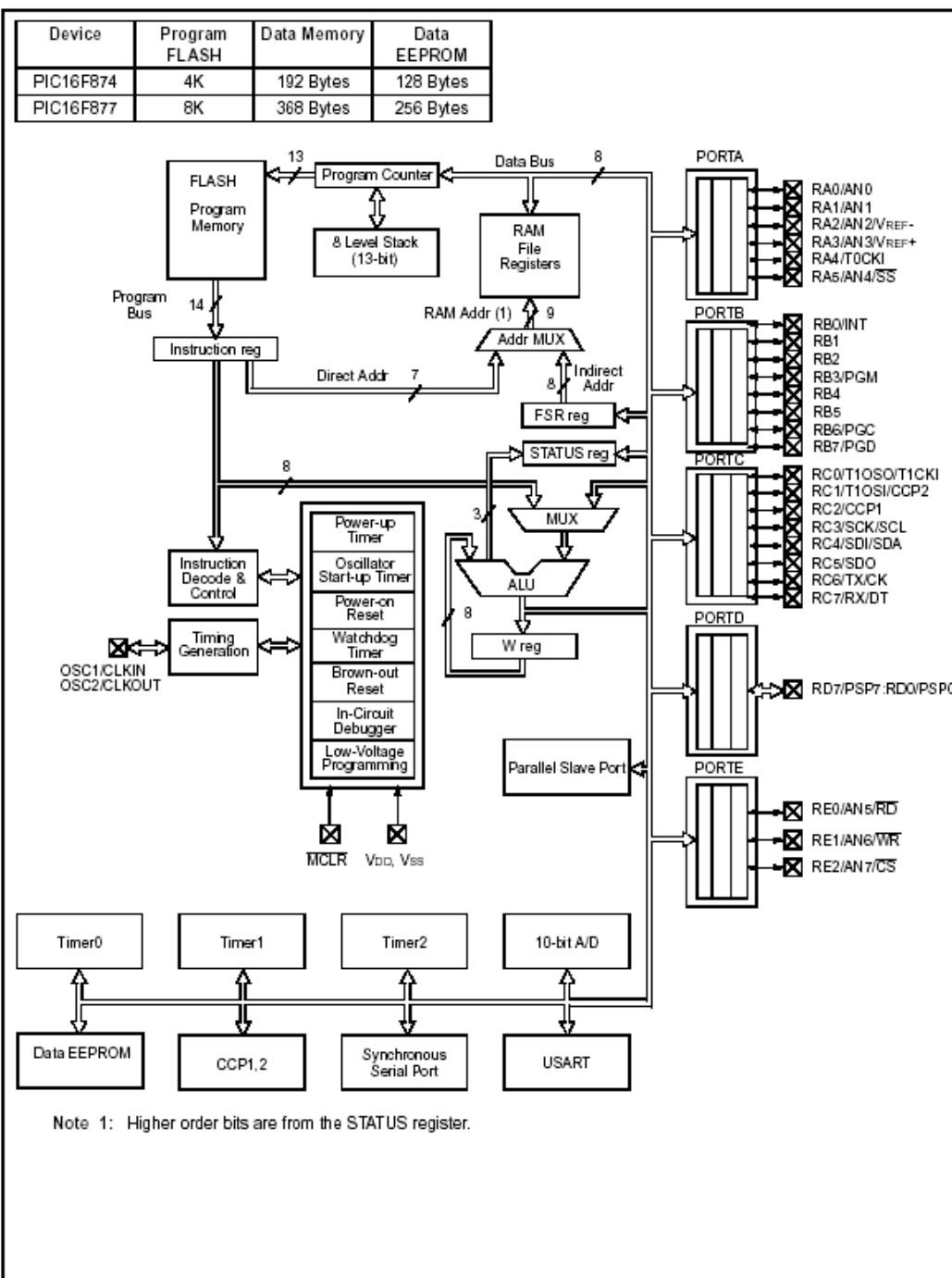

TABLE 1-2: PIC16F874 AND PIC16F877 PINOUT DESCRIPTION

Pin Name	DIP Pin#	PLCC Pin#	QFP Pin#	I/O/P Type	Buffer Type	Description
OSC 1/CLKIN	13	14	30	I	ST/CMOS ⁽⁴⁾	Oscillator crystal input/external clock source input.
OSC2/CLKOUT	14	15	31	O	—	Oscillator crystal output. Connects to crystal or resonator in crystal oscillator mode. In RC mode, OSC2 pin outputs CLKOUT which has 1/4 the frequency of OSC1, and denotes the instruction cycle rate.
MCLR/VPP/THV	1	2	18	I/P	ST	Master clear (reset) input or programming voltage input or high voltage test mode control. This pin is an active low reset to the device.
RA0/AN0	2	3	19	I/O	TTL	<p>PORTA is a bi-directional I/O port.</p> <p>RA0 can also be analog input0</p> <p>RA1 can also be analog input1</p> <p>RA2 can also be analog input2 or negative analog reference voltage</p> <p>RA3 can also be analog input3 or positive analog reference voltage</p> <p>RA4 can also be the clock input to the Timer0 timer/counter. Output is open drain type.</p> <p>RA5 can also be analog input4 or the slave select for the synchronous serial port.</p>
RA1/AN1	3	4	20	I/O	TTL	
RA2/AN2/REF-	4	5	21	I/O	TTL	
RA3/AN3/REF+	5	6	22	I/O	TTL	
RA4/T0CKI	6	7	23	I/O	ST	
RA5/SS/AN4	7	8	24	I/O	TTL	
RB0/INT	33	36	8	I/O	TTL/ST ⁽¹⁾	<p>PORTB is a bi-directional I/O port. PORTB can be software programmed for internal weak pull-up on all inputs.</p> <p>RB0 can also be the external interrupt pin.</p> <p>RB3 can also be the low voltage programming input</p> <p>Interrupt on change pin.</p> <p>Interrupt on change pin.</p> <p>Interrupt on change pin or In-Circuit Debugger pin. Serial programming clock.</p> <p>Interrupt on change pin or In-Circuit Debugger pin. Serial programming data.</p>
RB1	34	37	9	I/O	TTL	
RB2	35	38	10	I/O	TTL	
RB3/PGM	36	39	11	I/O	TTL	
RB4	37	41	14	I/O	TTL	
RB5	38	42	15	I/O	TTL	
RB6/PGC	39	43	16	I/O	TTL/ST ⁽²⁾	
RB7/PGD	40	44	17	I/O	TTL/ST ⁽²⁾	
RC0/T1OSO/T1CKI	15	16	32	I/O	ST	<p>PORTC is a bi-directional I/O port.</p> <p>RC0 can also be the Timer1 oscillator output or a Timer1 clock input.</p> <p>RC1 can also be the Timer1 oscillator input or Capture2 input/Compare2 output/PWM2 output.</p> <p>RC2 can also be the Capture1 input/Compare1 output/PWM1 output.</p> <p>RC3 can also be the synchronous serial clock input/output for both SPI and I²C modes.</p> <p>RC4 can also be the SPI Data In (SPI mode) or data I/O (I²C mode).</p> <p>RC5 can also be the SPI Data Out (SPI mode).</p> <p>RC6 can also be the USART Asynchronous Transmit or Synchronous Clock.</p> <p>RC7 can also be the USART Asynchronous Receive or Synchronous Data.</p>
RC1/T1OSI/CCP2	16	18	35	I/O	ST	
RC2/CCP1	17	19	36	I/O	ST	
RC3/SCK/SCL	18	20	37	I/O	ST	
RC4/SDI/SDA	23	25	42	I/O	ST	
RC5/SDO	24	26	43	I/O	ST	
RC6/TX/CK	25	27	44	I/O	ST	
RC7/RX/DT	26	29	1	I/O	ST	

Legend: I = input O = output I/O = input/output P = power
 — = Not used TTL = TTL input ST = Schmitt Trigger input

- Note 1: This buffer is a Schmitt Trigger input when configured as an external interrupt.
 2: This buffer is a Schmitt Trigger input when used in serial programming mode.
 3: This buffer is a Schmitt Trigger input when configured as general purpose I/O and a TTL input when used in the Parallel Slave Port mode (for interfacing to a microprocessor bus).
 4: This buffer is a Schmitt Trigger input when configured in RC oscillator mode and a CMOS input otherwise.

TABLE 1-2: PIC16F874 AND PIC16F877 PINOUT DESCRIPTION (CONTINUED)

Pin Name	DIP Pin#	PLCC Pin#	QFP Pin#	I/O/P Type	Buffer Type	Description
RD0/PSP0	19	21	38	I/O	ST/TTL ⁽³⁾	PORTD is a bi-directional I/O port or parallel slave port when interfacing to a microprocessor bus.
RD1/PSP1	20	22	39	I/O	ST/TTL ⁽³⁾	
RD2/PSP2	21	23	40	I/O	ST/TTL ⁽³⁾	
RD3/PSP3	22	24	41	I/O	ST/TTL ⁽³⁾	
RD4/PSP4	27	30	2	I/O	ST/TTL ⁽³⁾	
RD5/PSP5	28	31	3	I/O	ST/TTL ⁽³⁾	
RD6/PSP6	29	32	4	I/O	ST/TTL ⁽³⁾	
RD7/PSP7	30	33	5	I/O	ST/TTL ⁽³⁾	
RE0/ $\overline{\text{RD}}$ /AN5	8	9	25	I/O	ST/TTL ⁽³⁾	PORTE is a bi-directional I/O port. RE0 can also be read control for the parallel slave port, or analog input5. RE1 can also be write control for the parallel slave port, or analog input6. RE2 can also be select control for the parallel slave port, or analog input7.
RE1/ $\overline{\text{WR}}$ /AN6	9	10	26	I/O	ST/TTL ⁽³⁾	
RE2/ $\overline{\text{CS}}$ /AN7	10	11	27	I/O	ST/TTL ⁽³⁾	
VSS	12,31	13,34	6,29	P	—	Ground reference for logic and I/O pins.
VDD	11,32	12,35	7,28	P	—	Positive supply for logic and I/O pins.
NC	—	1,17,28,40	12,13,33,34		—	These pins are not internally connected. These pins should be left unconnected.

Legend: I = input O = output I/O = input/output P = power
 — = Not used TTL = TTL input ST = Schmitt Trigger input

- Note 1: This buffer is a Schmitt Trigger input when configured as an external interrupt.
 2: This buffer is a Schmitt Trigger input when used in serial programming mode.
 3: This buffer is a Schmitt Trigger input when configured as general purpose I/O and a TTL input when used in the Parallel Slave Port mode (for interfacing to a microprocessor bus).
 4: This buffer is a Schmitt Trigger input when configured in RC oscillator mode and a CMOS input otherwise.

FIGURE 2-3: PIC16F877/876 REGISTER FILE MAP

						File Address	
Indirect addr. ^(*)	00h	Indirect addr. ^(*)	80h	Indirect addr. ^(*)	100h	Indirect addr. ^(*)	180h
TMR0	01h	OPTION_REG	81h	TMR0	101h	OPTION_REG	181h
PCL	02h	PCL	82h	PCL	102h	PCL	182h
STATUS	03h	STATUS	83h	STATUS	103h	STATUS	183h
FSR	04h	FSR	84h	FSR	104h	FSR	184h
PORTA	05h	TRISA	85h		105h		185h
PORTB	06h	TRISB	86h	PORTB	106h	TRISB	186h
PORTC	07h	TRISC	87h		107h		187h
PORTD ^(*)	08h	TRISD ^(*)	88h		108h		188h
PORTE ^(*)	09h	TRISE ^(*)	89h		109h		189h
PCLATH	0Ah	PCLATH	8Ah	PCLATH	10Ah	PCLATH	18Ah
INTCON	0Bh	INTCON	8Bh	INTCON	10Bh	INTCON	18Bh
PIR1	0Ch	PIE1	8Ch	EEDATA	10Ch	EECON1	18Ch
PIR2	0Dh	PIE2	8Dh	EEADR	10Dh	EECON2	18Dh
TMR1L	0Eh	PCON	8Eh	EEDATH	10Eh	Reserved ⁽²⁾	18Eh
TMR1H	0Fh		8Fh	EEADRH	10Fh	Reserved ⁽²⁾	18Fh
T1CON	10h		90h		110h		190h
TMR2	11h	SSPCON2	91h		111h		191h
T2CON	12h	PR2	92h		112h		192h
SSPBUF	13h	SSPADD	93h		113h		193h
SSPCON	14h	SSPSTAT	94h		114h		194h
CCPR1L	15h		95h		115h		195h
CCPR1H	16h		96h		116h		196h
CCP1CON	17h		97h	General Purpose Register 16 Bytes	117h	General Purpose Register 16 Bytes	197h
RCSTA	18h	TXSTA	98h		118h		198h
TXREG	19h	SPBRG	99h		119h		199h
RCREG	1Ah		9Ah		11Ah		19Ah
CCPR2L	1Bh		9Bh		11Bh		19Bh
CCPR2H	1Ch		9Ch		11Ch		19Ch
CCP2CON	1Dh		9Dh		11Dh		19Dh
ADRESH	1Eh	ADRESL	9Eh		11Eh		19Eh
ADCON0	1Fh	ADCON1	9Fh		11Fh		19Fh
	20h		A0h		120h		1A0h
General Purpose Register 96 Bytes		General Purpose Register 80 Bytes		General Purpose Register 80 Bytes		General Purpose Register 80 Bytes	
	7Fh	accesses 70h-7Fh	EFh F0h	accesses 70h-7Fh	16Fh 170h	accesses 70h - 7Fh	1EFh 1F0h
Bank 0		Bank 1	FFh	Bank 2	17Fh	Bank 3	

Unimplemented data memory locations, read as '0'.
 * Not a physical register.

Note 1: These registers are not implemented on 28-pin devices.
Note 2: These registers are reserved, maintain these registers clear.

FIGURE 2-4: PIC16F874/873 REGISTER FILE MAP

						File Address	
Indirect addr. ^(*)	00h	Indirect addr. ^(*)	80h	Indirect addr. ^(*)	100h	Indirect addr. ^(*)	180h
TMR0	01h	OPTION_REG	81h	TMR0	101h	OPTION_REG	181h
PCL	02h	PCL	82h	PCL	102h	PCL	182h
STATUS	03h	STATUS	83h	STATUS	103h	STATUS	183h
FSR	04h	FSR	84h	FSR	104h	FSR	184h
PORTA	05h	TRISA	85h		105h		185h
PORTB	06h	TRISB	86h	PORTB	106h	TRISB	186h
PORTC	07h	TRISC	87h		107h		187h
PORTD ^(*)	08h	TRISD ^(*)	88h		108h		188h
PORTE ^(*)	09h	TRISE ^(*)	89h		109h		189h
PCLATH	0Ah	PCLATH	8Ah	PCLATH	10Ah	PCLATH	18Ah
INTCON	0Bh	INTCON	8Bh	INTCON	10Bh	INTCON	18Bh
PIR1	0Ch	PIE1	8Ch	EEDATA	10Ch	EECON1	18Ch
PIR2	0Dh	PIE2	8Dh	EEADR	10Dh	EECON2	18Dh
TMR1L	0Eh	PCON	8Eh	EEDATH	10Eh	Reserved ⁽²⁾	18Eh
TMR1H	0Fh		8Fh	EEADRH	10Fh	Reserved ⁽²⁾	18Fh
T1CON	10h		90h		110h		190h
TMR2	11h	SSPCON2	91h				
T2CON	12h	PR2	92h				
SSPBUF	13h	SSPADD	93h				
SSPCON	14h	SSPSTAT	94h				
CCPR1L	15h		95h				
CCPR1H	16h		96h				
CCP1CON	17h		97h				
RCSTA	18h	TXSTA	98h				
TXREG	19h	SPBRG	99h				
RCREG	1Ah		9Ah				
CCPR2L	1Bh		9Bh				
CCPR2H	1Ch		9Ch				
CCP2CON	1Dh		9Dh				
ADRESH	1Eh	ADRESL	9Eh				
ADCON0	1Fh	ADCON1	9Fh				
	20h		A0h		120h		1A0h
General Purpose Register		General Purpose Register		accesses 20h-7Fh		accesses A0h - FFh	
96 Bytes		96 Bytes			16Fh		1EFh
	7Fh		FFh		170h		1F0h
Bank 0		Bank 1		Bank 2	17Fh	Bank 3	1FFh

Unimplemented data memory locations, read as '0'.
 * Not a physical register.

Note 1: These registers are not implemented on 28-pin devices.
Note 2: These registers are reserved, maintain these registers clear.

11.0 ANALOG-TO-DIGITAL CONVERTER (A/D) MODULE

The Analog-to-Digital (A/D) Converter module has five inputs for the 28-pin devices and eight for the other devices.

The analog input charges a sample and hold capacitor. The output of the sample and hold capacitor is the input into the converter. The converter then generates a digital result of this analog level via successive approximation. The A/D conversion of the analog input signal results in a corresponding 10-bit digital number. The A/D module has high and low voltage reference input that is software selectable to some combination of VDD, VSS, RA2 or RA3.

The A/D converter has a unique feature of being able to operate while the device is in SLEEP mode. To operate in sleep, the A/D clock must be derived from the A/D's internal RC oscillator.

The A/D module has four registers. These registers are:

- A/D Result High Register (ADRESH)
- A/D Result Low Register (ADRESL)
- A/D Control Register0 (ADCON0)
- A/D Control Register1 (ADCON1)

The ADCON0 register, shown in Register 11-1, controls the operation of the A/D module. The ADCON1 register, shown in Register 11-2, configures the functions of the port pins. The port pins can be configured as analog inputs (RA3 can also be the voltage reference) or as digital I/O.

Additional information on using the A/D module can be found in the PICmicro™ Mid-Range MCU Family Reference Manual (DS33023).

REGISTER 11-1: ADCON0 REGISTER (ADDRESS: 1Fh)

R/W-0	R/W-0	R/W-0	R/W-0	R/W-0	R/W-0	U-0	R/W-0	
ADCS1	ADCS0	CHS2	CHS1	CHS0	GO/DONE	—	ADON	
							bit7	bit0

R = Readable bit
W = Writable bit
U = Unimplemented bit, read as '0'
- n = Value at POR reset

bit 7-6: **ADCS1:ADCS0:** A/D Conversion Clock Select bits
00 = Fosc/2
01 = Fosc/8
10 = Fosc/32
11 = FRC (clock derived from an RC oscillation)

bit 5-3: **CHS2:CHS0:** Analog Channel Select bits
000 = channel 0, (RA0/AN0)
001 = channel 1, (RA1/AN1)
010 = channel 2, (RA2/AN2)
011 = channel 3, (RA3/AN3)
100 = channel 4, (RA5/AN4)
101 = channel 5, (RE0/AN5)⁽¹⁾
110 = channel 6, (RE1/AN6)⁽¹⁾
111 = channel 7, (RE2/AN7)⁽¹⁾

bit 2: **GO/DONE:** A/D Conversion Status bit
If ADON = 1
1 = A/D conversion in progress (setting this bit starts the A/D conversion)
0 = A/D conversion not in progress (This bit is automatically cleared by hardware when the A/D conversion is complete)

bit 1: Unimplemented: Read as '0'

bit 0: **ADON:** A/D On bit
1 = A/D converter module is operating
0 = A/D converter module is shutoff and consumes no operating current

Note 1: These channels are not available on the 28-pin devices.

REGISTER 11-2: ADCON1 REGISTER (ADDRESS 9Fh)

U-0	U-0	R/W-0	U-0	R/W-0	R/W-0	R/W-0	R/W-0					
ADFM	—	—	—	PCFG3	PCFG2	PCFG1	PCFG0					R = Readable bit W = Writable bit U = Unimplemented bit, read as '0' - n = Value at POR reset
bit7							bit0					
<p>bit 7: ADFM: A/D Result format select 1 = Right Justified. 6 most significant bits of ADRESH are read as '0'. 0 = Left Justified. 6 least significant bits of ADRESL are read as '0'.</p> <p>bit 6-4: Unimplemented: Read as '0'</p> <p>bit 3-0: PCFG3:PCFG0: A/D Port Configuration Control bits</p>												
PCFG3: PCFG0	AN7 ⁽¹⁾ RE2	AN6 ⁽¹⁾ RE1	AN5 ⁽¹⁾ RE0	AN4 RA5	AN3 RA3	AN2 RA2	AN1 RA1	AN0 RA0	VREF+	VREF-	CHAN/ Refs ⁽²⁾	
0000	A	A	A	A	A	A	A	A	VDD	VSS	8/0	
0001	A	A	A	A	VREF+	A	A	A	RA3	VSS	7/1	
0010	D	D	D	A	A	A	A	A	VDD	VSS	5/0	
0011	D	D	D	A	VREF+	A	A	A	RA3	VSS	4/1	
0100	D	D	D	D	A	D	A	A	VDD	VSS	3/0	
0101	D	D	D	D	VREF+	D	A	A	RA3	VSS	2/1	
011x	D	D	D	D	D	D	D	D	VDD	VSS	0/0	
1000	A	A	A	A	VREF+	VREF-	A	A	RA3	RA2	6/2	
1001	D	D	A	A	A	A	A	A	VDD	VSS	6/0	
1010	D	D	A	A	VREF+	A	A	A	RA3	VSS	5/1	
1011	D	D	A	A	VREF+	VREF-	A	A	RA3	RA2	4/2	
1100	D	D	D	A	VREF+	VREF-	A	A	RA3	RA2	3/2	
1101	D	D	D	D	VREF+	VREF-	A	A	RA3	RA2	2/2	
1110	D	D	D	D	D	D	D	A	VDD	VSS	1/0	
1111	D	D	D	D	VREF+	VREF-	D	A	RA3	RA2	1/2	

A = Analog input
D = Digital I/O

Note 1: These channels are not available on the 28-pin devices.
2: This column indicates the number of analog channels available as A/D inputs and the number of analog channels used as voltage reference inputs.

The ADRESH:ADRESL registers contain the 10-bit result of the A/D conversion. When the A/D conversion is complete, the result is loaded into this A/D result register pair, the $\overline{\text{GO/DONE}}$ bit (ADCON0<2>) is cleared and the A/D interrupt flag bit ADIF is set. The block diagram of the A/D module is shown in Figure 11-1.

After the A/D module has been configured as desired, the selected channel must be acquired before the conversion is started. The analog input channels must have their corresponding TRIS bits selected as inputs. To determine sample time, see Section 11.1. After this acquisition time has elapsed, the A/D conversion can be started. The following steps should be followed for doing an A/D conversion:

1. Configure the A/D module:
 - Configure analog pins / voltage reference / and digital I/O (ADCON1)
 - Select A/D input channel (ADCON0)
 - Select A/D conversion clock (ADCON0)
 - Turn on A/D module (ADCON0)
2. Configure A/D interrupt (if desired):
 - Clear ADIF bit
 - Set ADIE bit
 - Set GIE bit
3. Wait the required acquisition time.
4. Start conversion:
 - Set $\overline{\text{GO/DONE}}$ bit (ADCON0)
5. Wait for A/D conversion to complete, by either:
 - Polling for the $\overline{\text{GO/DONE}}$ bit to be cleared
 OR
 - Waiting for the A/D interrupt
6. Read A/D Result register pair (ADRESH:ADRESL), clear bit ADIF if required.
7. For next conversion, go to step 1 or step 2 as required. The A/D conversion time per bit is defined as TAD. A minimum wait of 2TAD is required before next acquisition starts.

FIGURE 11-1: A/D BLOCK DIAGRAM

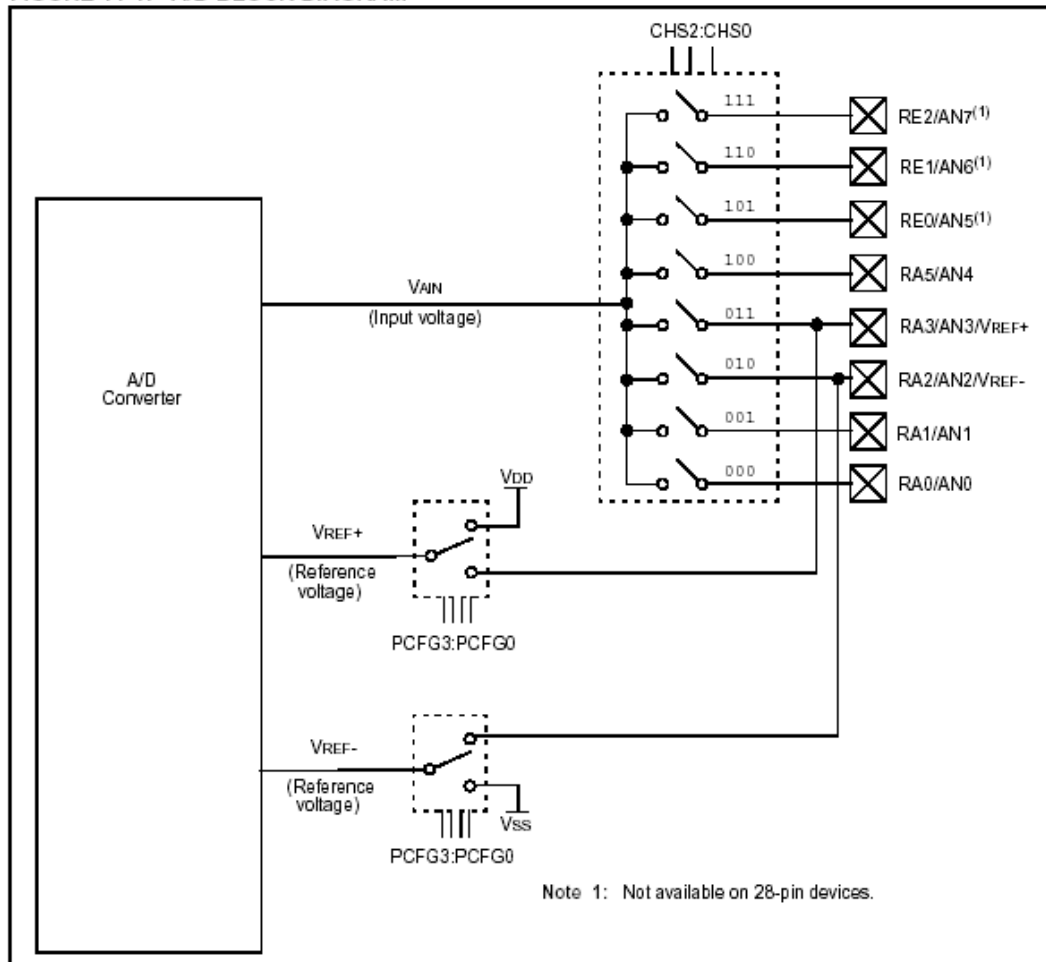

11.1 A/D Acquisition Requirements

For the A/D converter to meet its specified accuracy, the charge holding capacitor (CHOLD) must be allowed to fully charge to the input channel voltage level. The analog input model is shown in Figure 11-2. The source impedance (R_S) and the internal sampling switch (RSS) impedance directly affect the time required to charge the capacitor CHOLD. The sampling switch (RSS) impedance varies over the device voltage (V_{DD}), Figure 11-2. **The maximum recommended impedance for analog sources is 10 k Ω .** As the impedance is decreased, the acquisition time may be decreased. After the analog input channel is selected (changed), this acquisition must be done before the conversion can be started.

To calculate the minimum acquisition time, Equation 11-1 may be used. This equation assumes that 1/2 LSB error is used (1024 steps for the A/D). The 1/2 LSB error is the maximum error allowed for the A/D to meet its specified resolution.

To calculate the minimum acquisition time, T_{ACQ} , see the PICmicro™ Mid-Range Reference Manual (DS33023).

EQUATION 11-1: ACQUISITION TIME

$$\begin{aligned}
 T_{ACQ} &= \text{Amplifier Settling Time} + \\
 &\quad \text{Hold Capacitor Charging Time} + \\
 &\quad \text{Temperature Coefficient} \\
 &= T_{AMP} + T_C + T_{COFF} \\
 &= 2\mu\text{S} + T_C + [(\text{Temperature} - 25^\circ\text{C}) (0.05\mu\text{S}/^\circ\text{C})] \\
 T_C &= \text{CHOLD} (R_{IC} + R_{SS} + R_S) \ln(1/2047) \\
 &= -120\text{pF} (1\text{k}\Omega + 7\text{k}\Omega + 10\text{k}\Omega) \ln(0.0004885) \\
 &= 16.47\mu\text{S} \\
 T_{ACQ} &= 2\mu\text{S} + 16.47\mu\text{S} + [(50^\circ\text{C} - 25^\circ\text{C}) (0.05\mu\text{S}/^\circ\text{C})] \\
 &= 19.72\mu\text{S}
 \end{aligned}$$

Note 1: The reference voltage (VREF) has no effect on the equation, since it cancels itself out.

Note 2: The charge holding capacitor (CHOLD) is not discharged after each conversion.

Note 3: The maximum recommended impedance for analog sources is 10 k Ω . This is required to meet the pin leakage specification.

Note 4: After a conversion has completed, a 2.0TAD delay must complete before acquisition can begin again. During this time, the holding capacitor is not connected to the selected A/D input channel.

FIGURE 11-2: ANALOG INPUT MODEL
